

Hybrid Battery Controller HBC48-4



Main Features:

- Temperature compensation for VRLA Batteries.
- Synchronous and asynchronous modes of charging/discharging.
- No outage on transition or on controller fault. (default port continuity)
- Genset control (start on Voltage threshold and stop on battery charging current threshold).
- Auto CP and Genset variable charging current settings.
- Password Protected colored Display.
- Independent float and equalize charge voltage of each battery type.
- Independent charge and discharge current of each battery type.
- The technical parameters of each battery port for differential battery pack could be set independently.
- Real Time monitoring of operating parameters(SOC/SOH/DOD)of each battery.
- Support the sharing of lead-acid batteries, lithium batteries and super capacitors.
- Support lithium batteries for preferential discharging and lead-acid batteries as a back up.
- Support lithium battery cell over voltage, under voltage, over current, over heat cut-off protection.
- Support RS485/CAN communication with lithium batteries.
- Support installation on walls, cable ladder and embedded installation.

AGG HBC48-4 is used to decompose one dc voltage from a set of power supplies, into multiple dc voltages to meet differential battery packs for charging. When the battery is discharged, the **HBC48-4** also carries out the combined discharge of multiple battery packs, so as to ensure multiple battery packs running at the same time or different time by means of no interaction.

HBC48-4 adopts to solve the isolation problem of multiple groups cascaded batteries of different types, capacities and brands used in parallel to improve the comprehensive operating efficiency of battery assets as well as the power system.

Item:	Description
Input Voltage (DC)	40 V to 60 V
Output Voltage (DC)	42 V to 52.5 V
Floating Charge Voltage Setting Range	48 V to 58 V
Equalizing Charge Voltage Setting Range	48 V to 58 V
Charging Current (Each Port)	≥ 300 A
Discharging Current (Each Port)	≥ 300 A
Voltage Drop (max)	≤ 400 mV
Noise Voltage (Peak to Peak)	≤ 400 mV
Battery Port Number (Pcs)	4 Ports
Capacity per Battery Pack	≤ 1000 Ah
Efficiency	≥ 98%
Standby Power Consumption	≤ 10 W
Working Ambient Temperature	-15°C to 55°C
Storage Ambient Temperature	-40°C to 75°C
Communication Protocol	RS485/CAN
Dimensions (mm)	W = 442, D = 350, H = 87.5 (2U)
Weight	≤ 6.5 kg

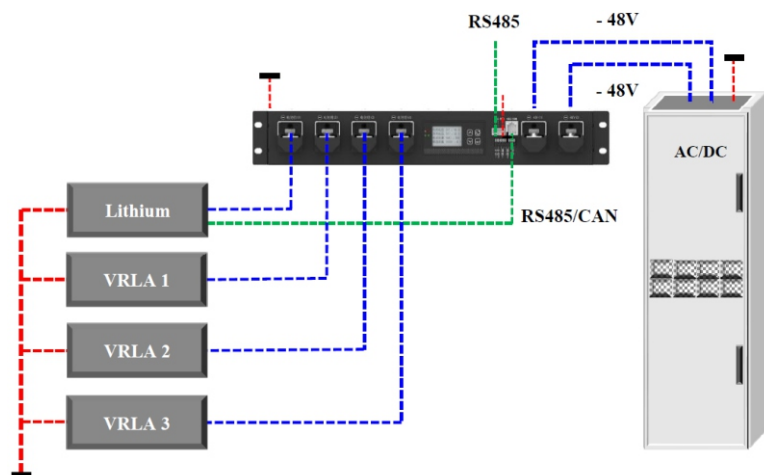

- | | | |
|-----------------------------|----------------------------------|--------------------------|
| 01. Battery connection port | 05. RS485 communication port | 09. Led indicator |
| 02. Failure indicator | 06. Signal ground | 10. Voltage acquisition |
| 03. LCD display screen | 07. RS485/CAN communication port | 11. Temp. detection |
| 04. Operation key | 08. power supply input port | 12. Fault warning output |

Copyright © AGG Network Solutions Co., Ltd. 2020. All rights reserved.
No part of this document may be reproduced or transmitted in any form or by any means without prior written consent of AGG Network Solutions Co., Ltd.

General Disclaimer:

The information in this document may contain predictive statements including, without limitation, statements regarding the future financial and operating results, future product portfolio, new technology, etc. There are a number of factors that could cause actual results and developments to differ materially from those expressed or implied in the predictive statements. Therefore, such information is provided for reference purpose only and constitutes neither an offer nor an acceptance. AGG Network Solutions Co., Ltd. may change the information at any time without notice.



AGG NETWORK SOLUTIONS CO., LTD.
AGG Industries
Bantian Longgang
Shenzhen 518129,
Singapore
Tel: +86-755-28780808
www.aggnetworksolutions.com